



# 400MM HORIZONTAL BANDSAW WITH HYDRAULIC ARM

MODEL NO: **SM353CE.V3**

Thank you for purchasing a Sealey product. Manufactured to a high standard, this product will, if used according to these instructions, and properly maintained, give you years of trouble free performance.

**IMPORTANT:** PLEASE READ THESE INSTRUCTIONS CAREFULLY. NOTE THE SAFE OPERATIONAL REQUIREMENTS, WARNINGS & CAUTIONS. USE THE PRODUCT CORRECTLY AND WITH CARE FOR THE PURPOSE FOR WHICH IT IS INTENDED. FAILURE TO DO SO MAY CAUSE DAMAGE AND/OR PERSONAL INJURY AND WILL INVALIDATE THE WARRANTY. KEEP THESE INSTRUCTIONS SAFE FOR FUTURE USE.



Refer to instructions



Wear eye protection



Wear ear protection



Wear protective clothing



Wear protective gloves



Wear safety footwear



Indoor use only



Electrical shock hazard

## 1. SAFETY

### 1.1. ELECTRICAL SAFETY

- ❑ **WARNING!** It is the user's responsibility to check the following:

Check all electrical equipment and appliances to ensure that they are safe before using. Inspect power supply leads, plugs and all electrical connections for wear and damage. Sealey recommend that an RCD (Residual Current Device) is used with all electrical products. You may obtain an RCD by contacting your local Sealey Stockist.

If the product is used in the course of business duties, it must be maintained in a safe condition and routinely PAT (Portable Appliance Test) tested.

**Electrical safety information, it is important that the following information is read and understood.**

- 1.1.1. Ensure that the insulation on all cables and on the appliance is safe before connecting it to the power supply.
- 1.1.2. Regularly inspect power supply cables and plugs for wear or damage and check all connections to ensure that they are secure.
- 1.1.3. **Important:** Ensure that the voltage rating on the appliance suits the power supply to be used and that the plug is fitted with the correct fuse - see fuse rating in these instructions.
  - × **DO NOT** pull or carry the appliance by the power cable.
  - × **DO NOT** pull the plug from the socket by the cable.
  - × **DO NOT** use worn or damaged cables, plugs or connectors. Ensure that any faulty item is repaired or is replaced immediately by a qualified electrician.
- 1.1.4. This product is fitted with a BS1363/A 13 Amp 3 pin plug.
  - If the cable or plug is damaged during use, switch the electricity supply off and remove from use. Ensure that repairs are carried out by a qualified electrician.
  - Replace a damaged plug with a BS1363/A 13 Amp 3 pin plug. If in doubt contact a qualified electrician.
    - a) Connect the GREEN/YELLOW earth wire to the earth terminal 'E'.
    - b) Connect the BROWN live wire to the live terminal 'L'.
    - c) Connect the BLUE neutral wire to the neutral terminal 'N'.
  - Ensure that the cable outer sheath extends inside the cable restraint and that the restraint is tight.
  - Sealey recommend that repairs are carried out by a qualified electrician.

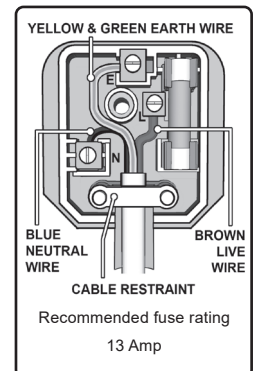

### 1.2. GENERAL SAFETY

- ✓ Familiarise yourself with the application and limitations of the saw, as well as the specific potential hazards.
- ✓ Ensure that all Health and Safety, local authority, and general workshop practice regulations are strictly adhered to.
- ❑ **WARNING!** Take care lifting the bandsaw arm as it is heavy, and could, if not correctly lifted, affect the whole balance of the machine.
- × **DO NOT** operate the bandsaw unless all blade guards are installed and in proper working order.
- × **DO NOT** operate the bandsaw with the blade in the fully raised position.
- × **DO NOT** leave the machine running unattended.
- × **DO NOT** operate the machine if any parts are damaged or missing as this may cause failure and/or personal injury.
- × **DO NOT** use the bandsaw for a task it is not designed to perform.
- × **DO NOT** use damaged or deformed bandsaw blades.
- × **DO NOT** remove the safety guard whilst in use.
- × **DO NOT** hold the workpiece by hand.
- × **DO NOT** touch the workpiece immediately after cutting, it may be very hot.
- × **DO NOT** operate the machine when you are tired or under the influence of alcohol, drugs or intoxicating medication.
- ✓ Ensure the machine is situated on a solid surface, adequate for supporting the weight of the machine and the workpiece.
- ✓ Keep all guards and holding screws in place, tight and in good working order. Check regularly for damaged parts.
- ✓ Disconnect bandsaw from the electric power supply before changing accessories, making repairs or adjustments.
- ✓ Wear approved safety eye protection and ear defenders.
- ✓ Maintain correct balance and footing, ensure the floor is not slippery and wear non-slip rubber soled footwear.
- ✓ Always provide adequate support for long and heavy material.
- × **DO NOT** turn bandsaw on until the workpiece is secured in the vice and the blade has been positioned just above the workpiece.
- × **DO NOT** over tighten the blade as it will stretch and warp.
- × **DO NOT** allow children or untrained persons to operate the machine. Keep them away from the work area.
- ✓ Check the alignment of moving parts regularly; for safest performance keep the machine clean at all times.
- ✓ Turn off the machine before raising the blade
- ✓ Avoid unintentional starting.

- ✓ Remove, clean and inspect the blade brush regularly.
- ✓ Remove any adjusting keys and wrenches from the bandsaw before turning it on.
- ✓ Replace or repair damaged parts. Use recommended parts only; unauthorised parts may be dangerous and will invalidate the warranty.
- ✓ Keep hands and body clear of the work table when operating the bandsaw.
- ✓ Remove ill fitting clothing, ties and loose jewellery; tie back long hair.
- ✓ Ensure there are no flammable materials near the work area.
- ✓ When not in use isolate from the electric supply, slacken blade tension (see section 6.3). Ensure that the machine cannot be accessed by children.

## 2. INTRODUCTION

Manufactured to comply with Supply of Machinery (Safety) Directives 1992 (and amendments) and fully CE approved. Saw arms are fitted with hydraulic damping to prevent the arm being dropped onto the workpiece and to ensure smooth cutting performance. Coolant fluid system and main power controls are switched on 24V/230V combined circuits for extra safety (SM353CE only). Heavy-duty single phase electric motors with over-current sensor on SM353CE model to cut power in the event of blade jam.

## 3. SPECIFICATION

|   |                     |
|---|---------------------|
| Capacity 90° - Round:.....                      | Ø228mm              |
| Capacity 90° - Square/Rectangular (H x W):..... | 228 x 355mm         |
| Capacity 45° - Round:.....                      | Ø152mm              |
| Capacity 45° - Square/Rectangular (H x W):..... | 228 x 152mm         |
| Blade Size:.....                                | 3035 x 27 x 0.9mm   |
| Blade Speeds:.....                              | 21, 33, 42, 59m/min |
| No Load Speed:.....                             | 1400rpm             |
| Motor Power:.....                               | 1500W               |
| Supply:.....                                    | 230V                |

## 4. ASSEMBLY

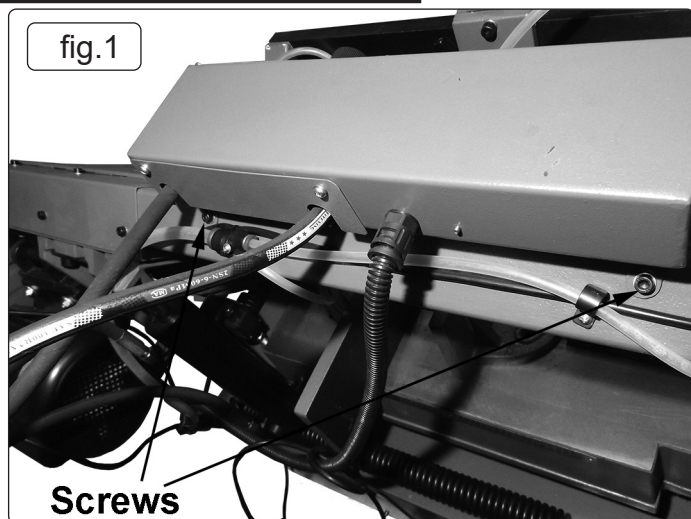

### 4.1. MOUNT CONTROL BOX ASSEMBLY FIG.1

- 4.1.1. Remove hex head bolts, lock washers and flat washers from column.
- 4.1.2. Secure control box to column using hex head bolts, lock washers and flat washers.

### 4.2. INSTALL MOTOR ASSEMBLY FIG 4

- 4.2.1. Remove socket head bolt, lock washer and flat washer from side of motor mount plate.
  - 4.2.2. Remove hex nut and flat washer from support shaft. Remove support shaft from motor mount bracket.
  - 4.2.3. Slide support shaft through motor mount bracket and motor tilt plate. Secure support shaft with hex nut and flat washer.
  - 4.2.4. Slide socket head bolt with lock washer and flat washer through slot in motor tilt plate and thread into motor mount plate.
- ✗ **DO NOT** tighten socket head bolt until V-belt is installed and adjusted.

### 4.3. MOUNT PULLEY COVER FIG 2

- 4.3.1. To open pulley cover remove knob from pulley cover.
- 4.3.2. Remove socket head bolts, lock washers and flat washers from drive wheel housing and motor mount bracket.
- 4.3.3. Secure pulley cover using socket head bolts, lock washers and flat washers.
- 4.3.4. Mount the pulley cover interlock. There are threaded holes that correspond with the holes on the interlock device (fig.3).

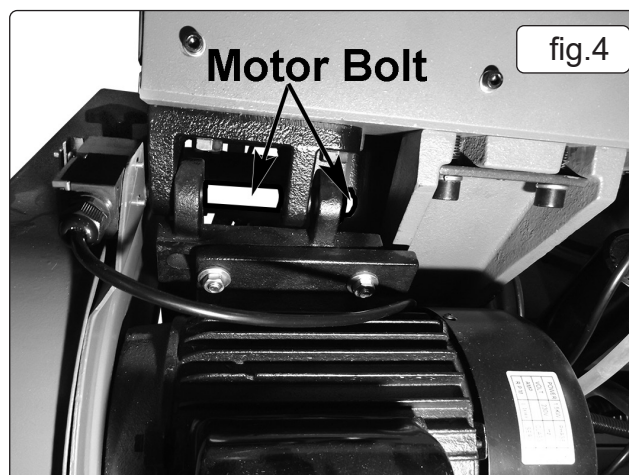
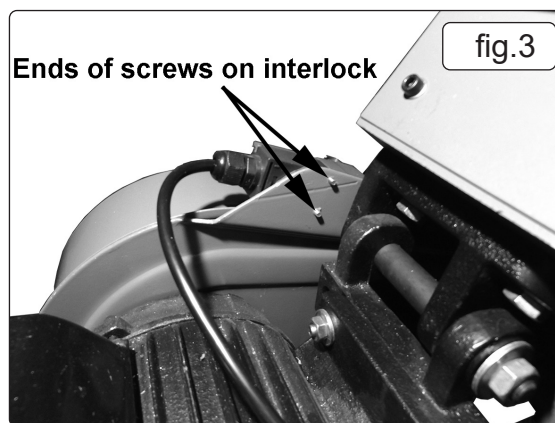
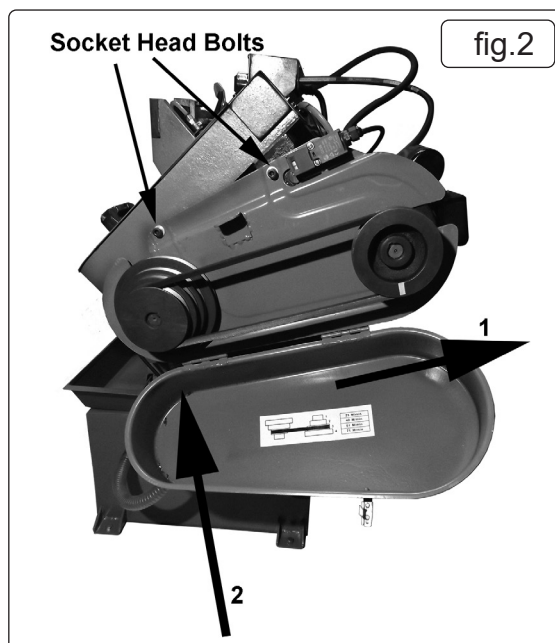

#### 4.4. INSTALL V-BELT

- 4.4.1. Band saw uses a step-pulley drive system to provide a selection of blade speeds.  
 4.4.2. Place V-belt on drive and motor pulleys with V-belt in desired location on pulleys. See Blade Speed Chart. (fig.5)

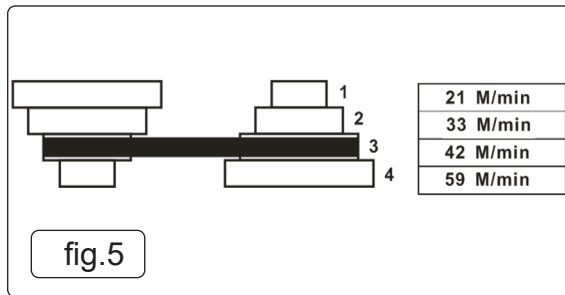

fig.5

\* **DO NOT** over tighten V-belt. Excessive tension on V-belt will reduce life of belt. Belt is properly tensioned when light pressure applied between pulleys produces about 1/2" deflection.

- 4.4.3. Tension V-belt by pushing motor mount plate and tightening socket head bolt (fig.7).  
 4.4.4. Close pulley cover and secure with knob.

#### 4.5. WIRE MOTOR FIG 6

- 4.5.1. Remove pan head screw and cover from motor junction box.  
 4.5.2. Pass motor cable through cable gland and secure cable with screw on strain relief.  
 4.5.3. Wire motor cable to motor with screws provided. Be sure to earth motor with green earthing wire in motor cable.  
 4.5.4. Replace junction box cover and secure with pan head screw.

#### 4.6. ATTACH WORK STOP ASSEMBLY (FIG.8)

- 4.6.1. Thread work stop rod into bed.  
 4.6.2. Slide work stop assembly onto work stop rod and secure with knob.  
 4.6.3. Adjust the support arm so as to be level with the vice for supporting flat sections.  
 4.6.4. To support tube sections, move the arm radially and use the thimble to support the inside of the tube.

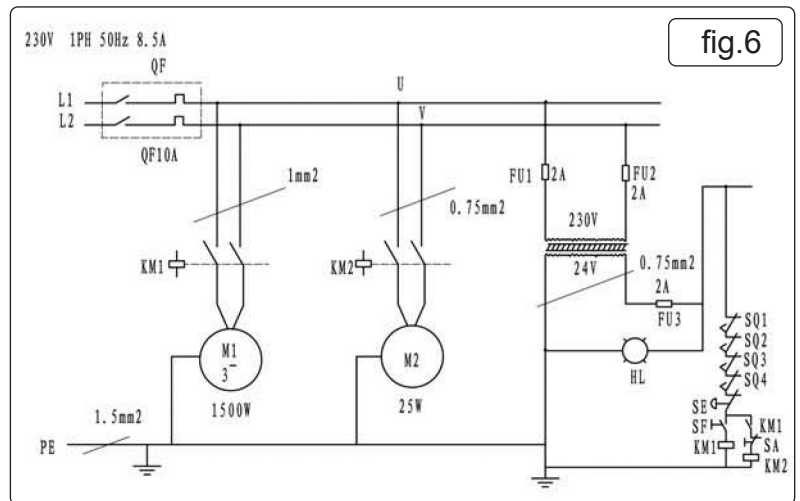

fig.6

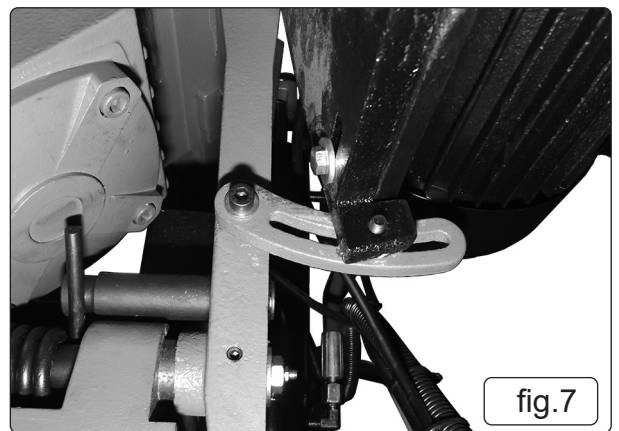

fig.7

## 5. INSTALLATION

**NOTE:** Before band saw is installed, a suitable location should be chosen. Band saw weighs approximately 279 Kg.

- 5.6.1. Band saw needs to be set on a flat level surface.  
 5.6.2. Make sure there is ample room for the workpiece.  
 5.6.3. Good lighting and correct power supply are also required for a proper work area.

#### 5.1. POWER SOURCE

- 5.1.1. Use only 3-wire extension cables having 3-prong grounding type plugs and 3-pole receptacles which accept the tool plug.  
 5.1.2. If the extension cable is worn, cut, or damaged in any way, replace it immediately.

## 6. OPERATION

#### 6.1. PRE USE CHECKS

- 6.1.1. The 9 x 16", 4-speed horizontal band saw blade speeds range from 82 to 235 FPM. Vice jaws can turn 0-45° for making angle cuts. Movable jaw has rapid approach and withdraw capability.

☐ **WARNING!** Whenever adjusting or replacing any parts on the band saw turn switch to off and remove plug from power source.

- 6.1.2. Make sure the stops are positioned and that the automatic shut-off is operating.  
 6.1.3. Check that the gear box has the proper amount of lubricant.  
 6.1.4. Make sure the blade guides are positioned correctly.  
 6.1.5. Use the appropriate blade for the workpiece that is being cut.  
 6.1.6. Use a sharp blade. Replace dull blades or blades which are missing teeth.  
 6.1.7. Make sure the blade is tensioned properly and going in the right direction.  
 6.1.8. Use the proper blade speed for the work.  
 6.1.9. For optimum performance, **DO NOT** stall the motor or reduce the speed. Use the proper feed pressure.  
 6.1.10. Make sure enough coolant is available to keep coolant pump submerged.  
 6.1.11. Secure the workpiece in a stable position.  
 6.1.12. Check that all guards are attached. After turning the switch on, let the blade come to full speed. Then lower the blade onto the workpiece slowly.  
 6.1.13. Keep hands away from the blade and all moving parts.

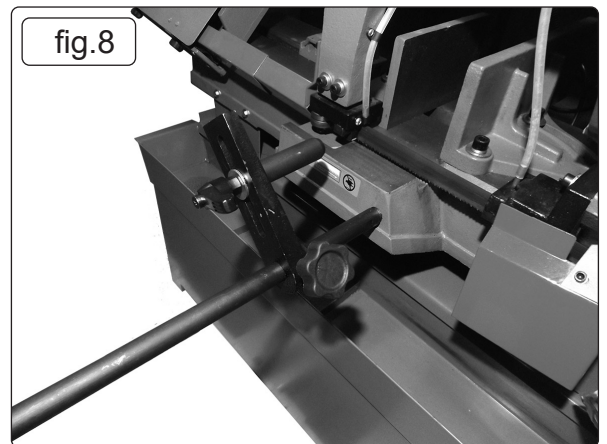

fig.8

6.1.14. Always wear eye protection.

## 6.2. OPERATING SAW CONTROLS FIG 9

6.2.1. Band saw control panel has SIX functional operations:

**POWER LIGHT** - White colour lamp that is illuminated when saw is plugged in.

**ON SWITCH** - Green colour push button that energizes the magnetic contactor to start the band saw.

**OFF/ EMERGENCY STOP** - Red colour push button that de-energizes the magnetic contactor to stop the band saw. To restart the saw, turn the knob to reset and depress the ON button.

**PUMP SWITCH** - Two position ON/OFF switch to operate the coolant pump.

**FEED REGULATOR** - Dial knob to set band saw feed rate. Set the feed rate suitable to application.

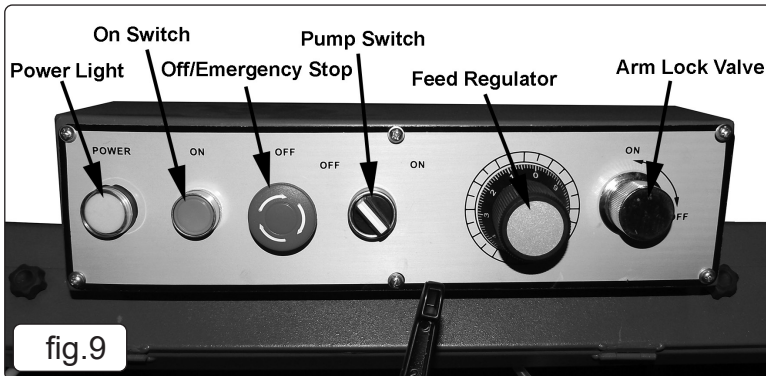

## 6.3. HORIZONTAL STOP (FIG.10)

6.3.1. Horizontal stop controls the position of the head at the end of the cut. Bed should contact the horizontal stop when teeth are 1/8" below the surface of the workbed.

6.3.2. Adjust the horizontal stop so that the teeth are 1/8" below the surface of the workbed.

6.3.3. Tighten the nut to lock the position.



## 6.4. AUTOMATIC SHUT OFF FIG.10

6.4.1. The limit switch is activated when the blade passes through the plane of the workbed. The limit switch should be activated as soon as the cut is finished.

**IMPORTANT:** Make sure the action of the limit switch is not restricted by the horizontal stop.

## 6.5. LUBRICATION

All ball bearings are permanently lubricated. They should not require further lubrication.

If the tracking wheel or head pivot is disassembled for any reason, wipe off the old grease before assembly.

## 6.6. BLADE GUIDES

6.6.1. Band saw blade has to be twisted relative to the plane in which it rotates.

6.6.2. Blade must be properly positioned relative to the workbed.

6.6.3. Blade guides hold the cutting portion of the blade in a plane which is perpendicular to both the workbed and the stationary vice and keeps the blade in line with its natural path around the blade wheels.

6.6.4. Inner guide bearings on the left and right guide assemblies keep the blade in line with the blade wheels. Outer guide bearings keep the blade against the inner bearings.

6.6.5. Entire guide assembly is positioned at the factory to produce the proper twist and should not need adjustment, however, the position of blade guides should be checked often.

**NOTE:** Since the blade position is related to both bed and the vice jaws, the relative position of the jaw to the bed is important. When assembled, the stationary jaw must be perpendicular to the surface of the workbed.

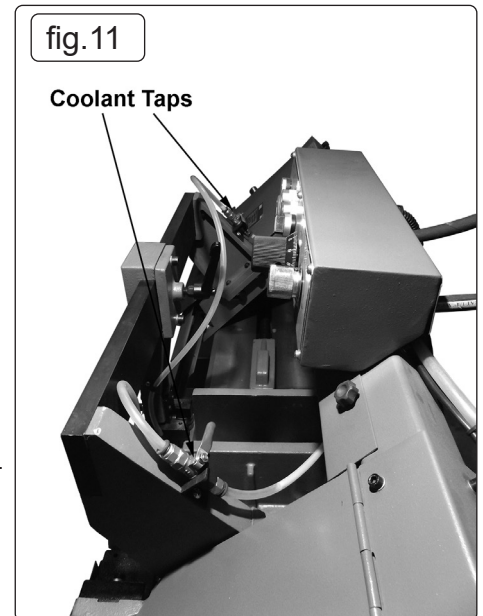
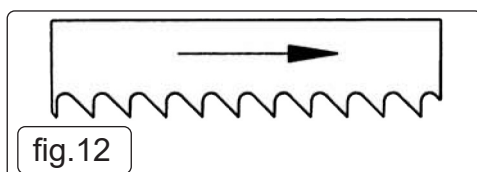

## 6.7. CHECKING BLADE GUIDES FIG13

- 6.7.1. Check that the blade teeth are perpendicular to the base's machined surface.
- 6.7.2. Spread the blade guides as far apart as possible.
- 6.7.3. Check that vice jaws are parallel and set for 90° cutoff.
- 6.7.4. Position the vice jaws to have the maximum separation that will not interfere with the blade guides.
- 6.7.5. With the head in horizontal position use a square against face of rear vice jaw and check that jaw is 90° to the side of blade.
- 6.7.6. Check that the blade is in line with drive and tracking wheels.
- 6.7.7. Raise the head.
- 6.7.8. Look straight on at the cutting edge of the blade.
- 6.7.9. Make sure that the blade sides are parallel to the sides of the bearings.
- 6.7.10. Make sure the bearings touch the blades and can still be rotated by hand.
- 6.7.11. Maintain eccentric shaft position and tighten socket head bolt.

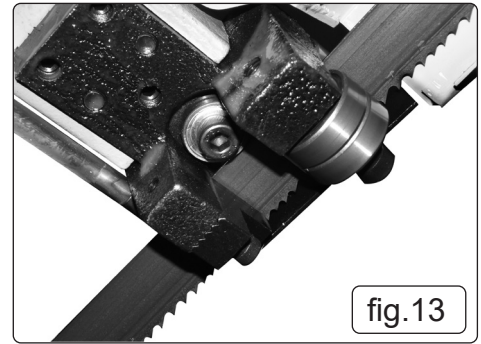

## 6.8. CHECKING THRUST BEARINGS

- 6.8.1. The thrust bearings should be .003-.005" (average thickness of a piece of paper) away from back of blade.
- 6.8.2. The thrust bearings are adjusted by moving the guide bracket.

## 6.9. ADJUSTING GUIDE BRACKETS

- 6.9.1. If the bearings are positioned properly and the blade is not square, one or both blade guide brackets must be adjusted.
- 6.9.2. Loosen the socket head bolts.
- 6.9.3. Adjust the bracket to the correct position.
- 6.9.4. Tighten the socket head bolt.
- 6.9.5. Check the guide bearings. Repositioning the blade guide bracket can alter the previous adjustments. Re-adjust if necessary.

## 6.10. BLADE SELECTION

- 6.10.1. Using the proper blade is important for setting up the correct cutting conditions. Blades are made differently depending on the specific application intended for the blade. Some simple rules can still be applied to almost all blades.
- 6.10.2. Always remember to have at least three teeth in contact with the work during a cut. When three teeth are in contact, the blade cannot straddle the work. This prevents a tooth that enters the cut from encountering more material than it can remove.
- 6.10.3. "Shocking" occurs when blade teeth contact too much material. This can strip the teeth from the blade. When cutting harder materials, the suggested minimum number of teeth in contact is six because "shocking" on harder materials has a more detrimental effect on the blade. Optimum number of teeth in contact with workpiece distributes blade forces among more teeth to increase cutting efficiency and reduces blade wear.
- 6.10.4. Optimum range is from 6-12 teeth in contact for soft materials, up to 12-24 teeth in contact for harder materials.
- 6.10.5. Always have maximum number of teeth in contact with work to prevent gullets of teeth from being clogged.
- 6.10.6. When choosing a blade, overall size of the work is not as important as the thickness average. Thickness average is the average width of material which blade will contact during each cut.
- 6.10.7. Thickness average should be used when choosing a blade for the optimum number of teeth in contact, however, the three teeth rule should be applied to the minimum thickness, not thickness average.
- 6.10.8. Keeping a selection of sharp blades on hand will yield better cuts. Blades may last longer because they are less likely to be misused when proper blade is available.
- 6.10.9. Every band saw should have at least one replacement blade of each type used. Blade breakage is unpredictable. Consult a blade manufacturer for detailed information about available blades for specific uses.

## 6.11. TRACKING

- 6.11.1. Proper tracking is achieved when the drive wheel and tracking wheel are aligned. A blade that is not tracking correctly can come off the blade wheels. Although adjustment is rarely required, tracking should be checked frequently.

**CAUTION** Turn motor off and, disconnect power to check tracking.

## 6.12. CHECK TRACKING

- 6.12.1. Prop open the blade wheel covers.
- 6.12.2. Insert a piece of paper between the blade and the lower portion of the tracking wheel.
- 6.12.3. Open the pulley cover and rotate the blade by turning the motor pulley.
- 6.12.4. Let the blade grab the paper. Rotate the pulley so the paper goes around the wheel.
- 6.12.5. Refer to Figure 14 to determine if an adjustment is needed.
- 6.12.6. A sharp fold indicates proper tracking.
- 6.12.7. Cut or ripped paper indicates that the blade is riding against the flange of the wheel. Adjusting bolt needs to be turned counter clockwise.
- 6.12.8. No fold indicates the blade will ride off the wheel. Adjusting bolt should be turned clockwise.

## 6.13. BLADE SPEED

- 6.13.1. Choosing the proper blade speed is important for extending the life of the blade. The speed determines the available cutting force.
- 6.13.2. Harder materials require more force and are cut at a slower speed.
- 6.13.3. Softer materials are cut with less force at higher speeds to ensure the proper removal of the chips.
- 6.13.4. The speed and corresponding force are related to the power supplied to the blade. Four speeds are available.
- 6.13.5. If a motor, other than the one supplied is used, the cutting conditions will be changed. Four speeds are available.
- 6.13.6. Speed is changed by moving V-Belt to one of the four pulley positions.

## 6.14. CHANGING BELT POSITION

- 6.14.1. Remove knob from pulley cover.
- 6.14.2. Open pulley cover. Loosen socket head bolt.
- 6.14.3. Move the belt to the desired position.
- 6.14.4. Tighten the socket head bolt to tension the belt. Belt is tensioned properly when a moderate pressure applied to the belt between the pulleys produces a 1/2" of deflection.
- 6.14.5. Secure pulley cover with knob.

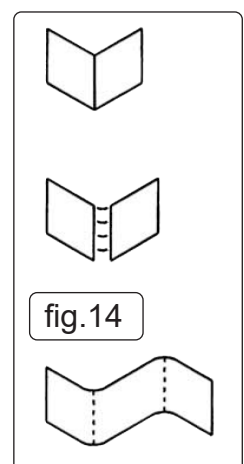

## 6.15. FEED PRESSURE

- 6.15.1. Correct feed pressure holds the blade in the cut. Feed pressure is supplied by the weight of the head. Maximum material removal rate corresponds with the proper pressure. Optimum feed pressure ensures that maximum power is used for cutting. If the feed pressure is too low, the blade will not dig into the material properly. Too much feed pressure will cause the blade to dig too deeply, bogging down the motor, and possibly burning it out. In addition, blade "shocking" could result.
- 6.15.2. Feed pressure is controlled by the feed regulator. The regulator creates a force which counteracts the feed pressure. The force from the feed regulator can be adjusted to create any feed pressure up to the set maximum.
- 6.15.3. Having the correct feed pressure will produce the optimum feed rate and the fastest cut. Incorrect pressure, whether too great or too small, will put less power into the cut and reduce the feed rate.
- 6.15.4. Curled shavings indicate correct feed pressure.
- 6.15.5. Thick discontinuous chips indicate too much pressure. Turn knob clockwise.
- 6.15.6. Powdery chips indicate too little pressure. Turn knob counter clockwise.
- 6.15.7. Extra energy will be used to produce powdered chips rather than smooth shavings; this will produce more heat and dull the blade.

## 6.16. COOLANT TANK

- 6.16.1. The coolant reservoir can hold up to four and a half gallons of coolant. For proper operation, the pump must be completely submerged in fluid.
- 6.16.2. Check that the fluid level is sufficient before attempting wet-cut operations. Usually four gallons is sufficient.
- 6.16.3. Check that the tank is not filled with debris.
- WARNING! DO NOT** allow shavings to flow through the pump. Change the fluid and clean the tank often. Whenever possible, the chips should be cleaned out of the chip tray before they are washed into coolant reservoir.

## 6.17. POSITIONING FIG 15

- 6.17.1. The vice is designed to keep the workpiece steady while it is being cut. The vice should only have to counteract the cutting forces. Using the proper position will help produce a safe and accurate cut. These general rules about positioning apply to most situations:
- ✓ The workpiece should rest flat on the workbed without the need for side support.
  - ✓ The entire length of the work should be supported.
  - ✗ **DO NOT** balance the work piece on the workbed. Use support stands to prevent the work from falling off after the cut.
  - ✓ Avoid positions which will cause the blade to encounter sharp edges. If sharp corners cannot be avoided, file down the point that the blade will contact.

## 6.18. CHECK THE BLADE PATH

- 6.19. Before the saw is plugged in, check to see that blade path is clear and that:
- ✓ All blade guards are in place.
  - ✓ There is no debris inside the blade guard or covers.
  - ✓ There is no debris on the blade or blade wheels.
  - ✓ All hoses and line cords are out of the blade path.
- WARNING DO NOT** operate saw unless all guards are in place and the workpiece is the only object that will encounter the blade teeth.

## 6.20. CUTTING FLUIDS

- 6.20.1. Using a cutting fluid can improve the cutting conditions and keep them more consistent throughout the cut by:
- 6.20.2. Lubricating the blade, which reduces the friction between it and the workpiece.
- 6.20.3. Taking heat away from the cut and preventing the workpiece and blade from overheating.
- 6.20.4. Dissipating the built-up heat because hot metals become tough and more difficult to cut and blades become dull at an accelerated rate.

**NOTE:** Because much of the built-up heat comes from friction between the blade and the workpiece, cutting fluids are often referred to as "coolants".

- 6.20.5. The importance of cutting fluids increases with blade speed and toughness of the material.
- 6.20.6. We recommend the use of either NCO/5L : Neat Cutting Oil 5L or SCO/5L : Soluble Cutting Oil 5L.

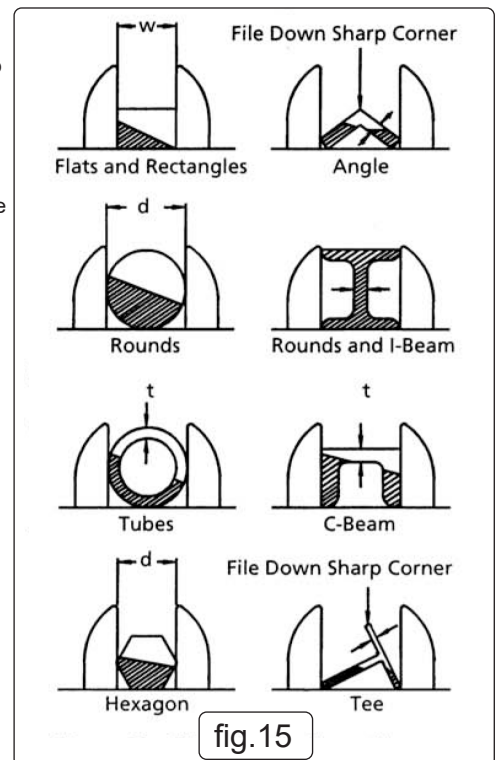

## 7. ADJUSTMENTS

### 7.1. HORIZONTAL STOP ADJUSTMENT

- 7.1.1. Place head in the horizontal position.
- 7.1.2. Loosen the nut on the horizontal stop.

### 7.2. TRACKING ADJUSTMENT

- 7.2.1. The tracking is adjusted by positioning the idler wheel shaft. The positioning is done with the hex head bolts only if the upper socket head bolts are loose.
- 7.2.2. Loosen the three socket head bolts.
- 7.2.3. Adjust the tilt with hex head bolts. For correct tracking, refer to Fig.6. Turn 1/4 revolution at a time.
- 7.2.4. Check the blade tension and adjust if necessary.
- 7.2.5. Recheck the tracking.
- 7.2.6. Once the proper position has been found, tighten the bolts securely.

### 7.3. ADJUSTING GUIDE BEARINGS

- 7.3.1. If the blade is not perpendicular to the bed or not in line with the blade wheels, adjustment is necessary.

**NOTE:** There should be .000-.001" clearance between the blade and the guide bearings.

- 7.3.2. The guide bearings are adjusted using an eccentric location system. The inner guide bearings are fixed and cannot be adjusted. The outer guide bearings are mounted to eccentric sleeves and can be adjusted.
- 7.3.3. Loosen socket head bolt with a wrench. Rotate the eccentric shaft to locate bearings in desired positions.

### 7.4. WORK STOP ADJUSTMENT

- 7.4.1. Loosen the knob holding the work stop casting to the work stop bar.
- 7.4.2. Adjust the work stop casting to the desired length position.

- 7.4.3. Rotate the work stop to contact the workpiece as close to the bottom as possible.
- 7.4.4. Tighten the knob.
- ✘ **DO NOT** allow the blade to rest on the workpiece while the motor is shut off.
- 7.4.5. When cutting rectangular stock, position the workpiece vertically instead of flat (fig.15.W). This is to reduce the amount of blade contact with the workpiece, which will result in more efficient sawing and a better-quality cut.
- 7.4.6. To provide blade support, position blade guide arms as close as possible to the workpiece. If the distance is too great, the blade can “wander” in the cut. Be aware of how much downfeed pressure is acting on the cut as this contributes to the blade wandering.

**NOTE:** See Blade Selection (6.10) for more information on thickness average calculation.

#### 7.5. ADJUSTING GUIDE BRACKETS

- 7.5.1. If the bearings are positioned properly and the blade is not square, one or both blade guide brackets must be adjusted.
- 7.5.2. Loosen the socket head bolts.
- 7.5.3. Adjust the bracket to the correct position.
- 7.5.4. Tighten the socket head bolt.
- 7.5.5. Check the guide bearings. Repositioning the blade guide bracket can alter the previous adjustments. Readjust if necessary.

#### 7.6. REGULATING FEED

- 7.6.1. Feed pressure is controlled by the feed regulator. The regulator creates a force which counteracts the feed pressure. The force from the feed regulator can be adjusted to create any feed pressure up to the set maximum.
- 7.6.2. Having the correct feed pressure will produce the optimum feed rate and the fastest cut. Incorrect pressure, whether too great or too small, will put less power into the cut and reduce the feed rate.

**NOTE:** Wasted power damages the saw.

- 7.6.3. Determining the proper feed is largely a judgement based on experience. The feed is usually determined during the cutting operation. Before the cutting begins, the blade should be off the work and the head should be held in position by placing the feed control knob in the OFF position.
- 7.6.4. Once the blade is running, the head is slowly lowered onto the work by turning the feed control knob to the on position, and adjusting the feed regulator knob to the desired feed rate.
- 7.6.5. After the blade begins the cut, optimum feed rate should be determined.
- 7.6.6. To determine if the feed is incorrect, examine the chips produced (fig.16). When the blade is operating at the ideal feed for the speed, the chips will be curled and continuous. If the chips are thick and not continuous, the feed pressure should be reduced. If the chips are powdery, the feed pressure by leaning on head.
- 7.6.7. Curled shavings indicate correct feed pressure.
- 7.6.8. Thick discontinuous chips indicate too much pressure. Turn knob clockwise.
- 7.6.9. Powdery chips indicate too little pressure. Turn knob counter clockwise.

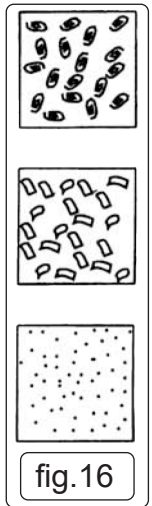

fig.16

## 8. MAINTENANCE

- 8.1. Steps required to keep the saw in optimum operating condition have been described under Operation. The Safety Precautions should be performed before operation.
- 8.2. For proper maintenance:
  - 8.2.1. Keep saw clean and dry. Sweep off spots where chips have collected and wipe off spots where coolant splashed.
  - 8.2.2. Lubricate the unpainted surfaces with a light application of medium consistency machine oil to prevent corrosion after cleaning.
  - 8.2.3. Grease the vice lead screw if vice action becomes difficult.
  - 8.2.4. Replace dull blades and blades from which teeth have been stripped. A clean saw with a sharp blade will yield the best cut.
  - 8.2.5. Internal parts of the band saw have been completely lubricated at the factory and **DO NOT** need to be lubricated again.
  - 8.2.6. After the first fifty hours of use, the gear box should be drained and refilled.
    - **WARNING** Make certain unit is disconnected from power source before attempting to service or remove any component. If power cable is worn, cut, or damaged in anyway, have it replaced immediately by a qualified electrician.

#### 8.3. OIL LEVEL

- 8.3.1. The gear box relies on an oil bath to lubricate the sliding surfaces and transfer heat. The vent bolt is vented to release pressure created by the developed heat. Insufficient lubrication will cause the gears to heat up and wear at and If the gear box is worked on, the oil should be replaced to avoid contamination. Always add fresh oil and replace the oil seasonally, to guard against breakdown. The seals between the gearbox and the cover plates are gaskets. If a cover plate is removed, the surface should be cleaned and new gasket should be applied. After the first fifty hours of use, the gear box should be drained and refilled with industrial gear oil.

#### 8.4. CHECKING OIL LEVEL

- 8.4.1. Place the head in the horizontal position.
- 8.4.2. Let the oil settle. Allow a few minutes if the head was in motion.
- 8.4.3. Check the fluid level. Look at the oil sight lens and follow the instructions (fig.18).  
Sight lens full of oil: Drain oil by removing drain plug.  
Sight lens half-covered: The oil level is correct.

#### 8.5. CHANGING THE BLADE

- **WARNING!** Disconnect band blades. Wear leather gloves when handling band saw blades. **DO NOT** wear gloves when operating saw.
- 8.5.1. Prop open the blade wheel covers.
- 8.5.2. Loosen the outer guide bearings on the left and right guide assemblies. No other guide bearings should be moved.
- 8.5.3. Remove knobs and blade guard.
- 8.5.4. With one hand, pinch the blade and the tracking wheel together to protect against the possibility of the blade popping

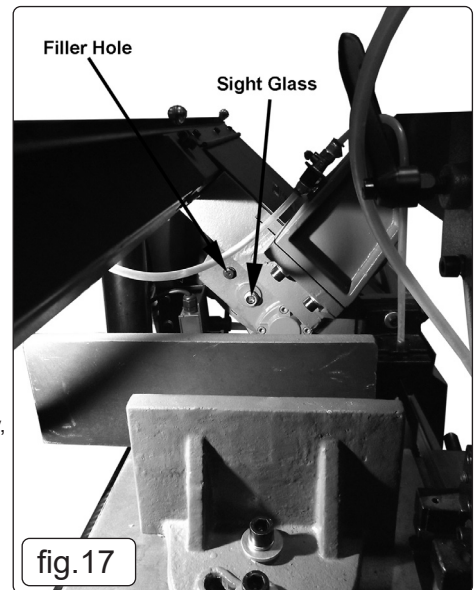

fig.17

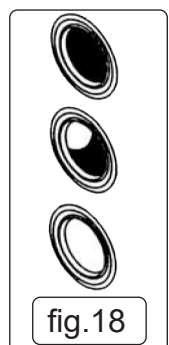

fig.18

off when tension is released.

8.5.5. Release the tension by slowly revolving the hand wheel counter clockwise.

8.5.6. Remove the blade.

**8.6. REPLACING THE BLADE**

8.6.1. Make sure the outer guide bearings are loose.

8.6.2. Make sure the teeth are pointing in the right direction.

8.6.3. Place the blade around the wheels and between the guide bearings.

8.6.4. Hold the blade in position and apply tension. Blade tension generally must be set at 25000 psi for hard back blades, and 35000 psi for bi-metal blades. Use tension scale (fig.19).

8.6.5. Push the blade against the wheel flange.

8.6.6. Tighten the blade until it is properly tensioned. A properly tightened blade will ring slightly when the back of the blade is plucked (like a string of an instrument).

8.6.7. Adjust the outer guide bearings.

8.6.8. Check for proper tracking (See Tracking Adjustment 7.2).

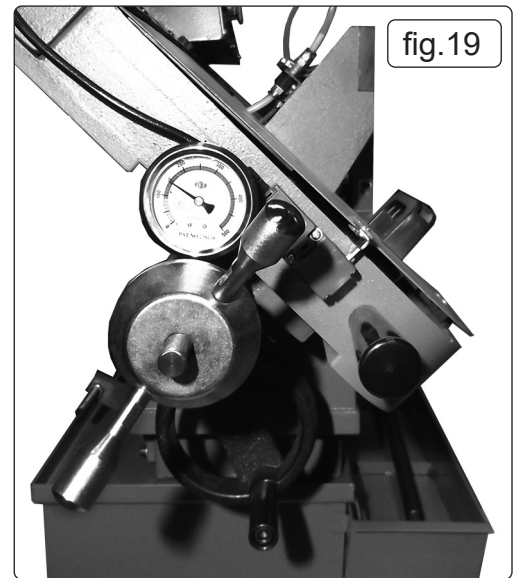

fig.19

**9. TROUBLESHOOTING**

| PROBLEM  | CAUSE  | SOLUTION  |
|--|--|---|
| Excessive blade breakage and/ or teeth ripping from the blade. | Workpiece is loose in the vice.<br>Incorrect speed or feed.<br>Blade is too coarse.<br>Workpiece is too course.<br>Incorrect blade tension.<br>Blade is in contact with workpiece when saw is started.<br>Blade is rubbing on the wheel flange.<br>Blade guides are misaligned.<br>Blade is too thick. | Clamp the workpiece securely.<br>Adjust the speed or feed to suit the workpiece.<br>Replace with a finer blade.<br>Use the saw at slower speed and use a finer blade.<br>Adjust blade tension.<br>Place blade in contact with the workpiece only after the saw has started.<br>Adjust tracking.<br>Adjust blade guides.<br>Use correct blade. |
| Premature blade dulling.                                       | Blade is too coarse.<br>Incorrect speed - too fast.<br>Inadequate feed<br>Hard spots or scale on the workpiece.<br>Blade is twisting.<br>Insufficient blade tension.<br>Blade is sliding.  | Replace with a finer blade.<br>Reduce blade speed.<br>Adjust hydraulic feed control and/or bow weight.<br>Reduce blade speed, increase feed pressure.<br>Replace blade and adjust to the correct tension.<br>Increase blade tension.<br>Increase blade tension and reduce blade speed.  |
| Unusual wear on side or back of blade.                         | Blade guides are worn.<br>Blade guides are misaligned.<br>Blade guide brackets are loose.  | Replace blade guides.<br>Adjust guide pivots.<br>Tighten blade guide brackets.  |
| Motor overheating.   | Blade tension too high.<br>Drive belt tension too high.<br>Blade too coarse or too fine.<br>Gears need lubrication.<br>Blade is binding in the cut.  | Reduce blade tension.<br>Reduce drive belt tension.<br>Use a blade more suitable for the workpiece.<br>Lubricate the gears.<br>Decrease feed and blade speed.   |
| Bad, crooked or rough cuts.                                    | Feed pressure too great.<br>Blade guides are misaligned.<br>Inadequate blade tension.<br>Blade is dull.<br>Incorrect speed.<br>Blade guides too far from workpiece.<br>Blade guide assembly is loose.<br>Blade is too coarse.  | Adjust hydraulic feed control and/or bow weight.<br>Adjust blade guides.<br>Increase blade tension.<br>Replace the blade.<br>Adjust the speed.<br>Adjust guides.<br>Tighten the guide assembly.<br>Use a finer blade.   |
| Blade twisting.  | Blade is binding in the cut.<br>Blade tension is too high.   | Adjust hydraulic feed control to decrease feed pressure.<br>Decrease blade tension.   |





#### WEEE REGULATIONS

Dispose of this product at the end of its working life in compliance with the EU Directive on Waste Electrical and Electronic Equipment (WEEE). When the product is no longer required, it must be disposed of in an environmentally protective way. Contact your local solid waste authority for recycling information.



#### ENVIRONMENT PROTECTION

Recycle unwanted materials instead of disposing of them as waste. All tools, accessories and packaging should be sorted, taken to a recycling centre and disposed of in a manner which is compatible with the environment. When the product becomes completely unserviceable and requires disposal, drain any fluids (if applicable) into approved containers and dispose of the product and fluids according to local regulations.

**Note:** It is our policy to continually improve products and as such we reserve the right to alter data, specifications and component parts without prior notice. Please note that other versions of this product are available. If you require documentation for alternative versions, please email or call our technical team on [technical@sealey.co.uk](mailto:technical@sealey.co.uk) or 01284 757505.

**Important:** No Liability is accepted for incorrect use of this product.

**Warranty:** Guarantee is 12 months from purchase date, proof of which is required for any claim.

Sealey Group, Kempson Way, Suffolk Business Park, Bury St Edmunds, Suffolk. IP32 7AR



01284 757500



01284 703534



[sales@sealey.co.uk](mailto:sales@sealey.co.uk)



[www.sealey.co.uk](http://www.sealey.co.uk)